

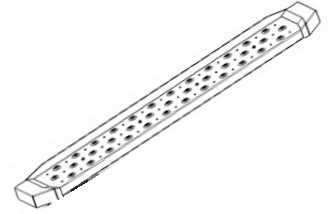

Running Board

Part No. RBW19B



Fits: Current Ford Ranger Supercab



60-180 min

Cutting is not Required

Drilling is not Required



REMOVE CONTENTS FROM BOX. VERIFY ALL PARTS ARE PRESENT.



support@trailfx.com



READ INSTRUCTIONS CAREFULLY BEFORE STARTING INSTALLATION.



1 866 638 4870

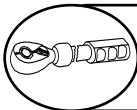

DO NOT OVER TORQUE. STANDARD OPERATING LOAD FOR TIGHTEN BODY MOUNT NUTS & BOLTS VARIES FROM 45 TO 65 FOOT POUND.



POLISHED STAINLESS STEEL - LIMITED LIFETIME
POWDER COATED BLACK - 3 YEARS

PARTS LIST:

Qty	Part Description	Qty	Part Description
2	Rattler Running Boards	12	10-1.5mm x 25mm Hex Bolts
1	Driver/Left Front Mounting Bracket	12	10mm Lock Washers
1	Passenger/Right Front Mounting Bracket	12	10mm x 27mm x 3mm Flat Washers
1	Driver/Left Center Mounting Bracket	6	6mm x 1.0mm x 30mm Double Bolt Plates
1	Passenger/Right Center Mounting Bracket	12	6mm x 22mm x 2mm Flat Washers
1	Driver/Left Rear Mounting Bracket	12	6mm Lock Washers
1	Passenger/Right Rear Mounting Bracket	12	6mm Hex Nuts

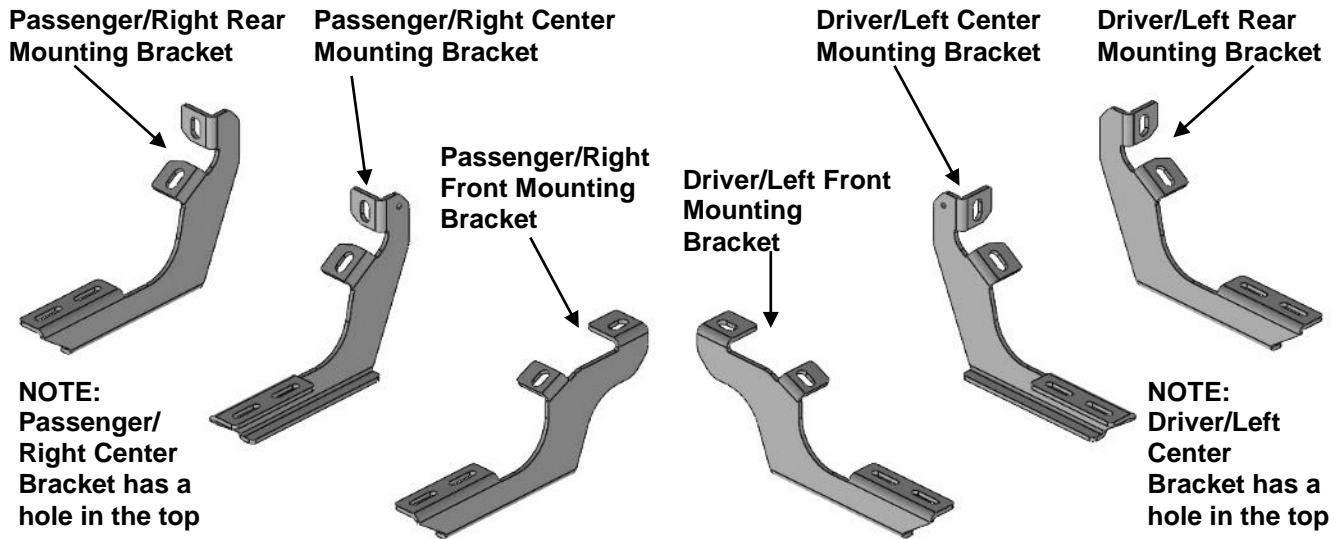

PROCEDURE:

REMOVE CONTENTS FROM BOX. VERIFY ALL PARTS ARE PRESENT. READ INSTRUCTIONS CAREFULLY BEFORE STARTING INSTALLATION. ASSISTANCE IS RECOMMENDED.

1. Start the installation under the Passenger/Right side of the vehicle. Locate the front factory mounting location along the inner side of the body, **(Figure 1)**.
2. Remove the plastic plugs covering the mounting holes. Select Passenger/Right Front Mounting Bracket. Attach to Passenger/Right front location with (2) 10mm x 25mm Hex Bolts, (2) 10mm Lock Washers and (2) 10mm Flat Washers **(Figure 2)**. Do not tighten hardware at this time.
3. Locate the center threaded mounting holes. Select Passenger/Right Center Mounting Bracket. Attach with (2) 10mm x 25mm Hex Bolts, (2) 10mm Lock Washers and (2) 10mm Flat Washers, **(Figures 3 &**

- 5). Do not tighten hardware at this time. **NOTE:** The Passenger/Right Center and Rear Mounting Brackets look similar, the bottom tabs face opposite directions and there is a small hole on the top of the Passenger/Right Center Mounting Bracket, (**Figure 4**).
4. Repeat **Step 3** to install Passenger/Right Rear Mounting Bracket, (**Figures 5 & 6**).
 5. Carefully unwrap and select the (1) Rattler Running Board.
 6. Place the Running Board on top of the Brackets. Locate the channel in the bottom of the Running Board. Select (3) 6mm Double Bolt Plates. Insert the Bolt Plates into the channel in the bottom of the Running Board closest to the Brackets, (**Figure 7**). Lift the Running Board up and guide the studs down through the Brackets.
 7. Attach the Running Board to the Brackets with (6) 6mm Flat Washers, (6) 6mm Lock Washers and (6) 6mm Hex Nuts, (**Figure 8**). Do not tighten hardware at this time.
 8. Level and adjust the Running Board as necessary and fully tighten all hardware.
 9. Repeat **Steps 1—8** for the Driver/Left side Running Board installation.
 10. Do periodic inspections to the installation to make sure that all hardware is secure and tight.

To protect your investment, Do not use any type of polish or wax that may contain abrasives that could damage the finish. Mild soap may be used also to clean the Running Board.

Passenger/Right Side Installation Pictured

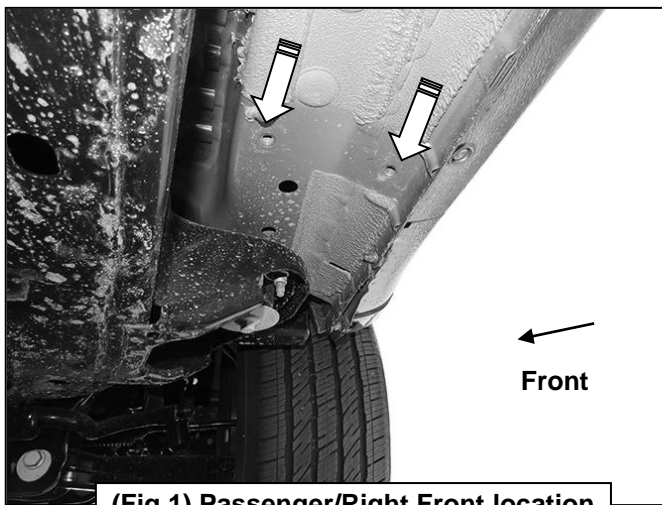

(Fig 1) Passenger/Right Front location

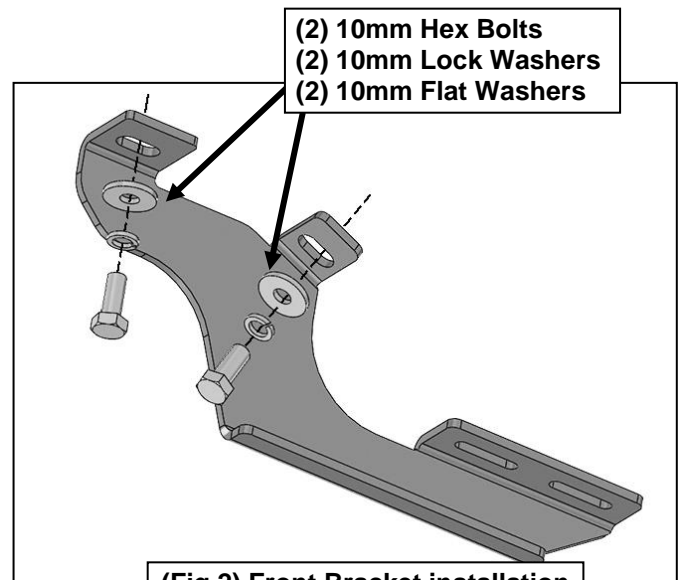

(Fig 2) Front Bracket installation

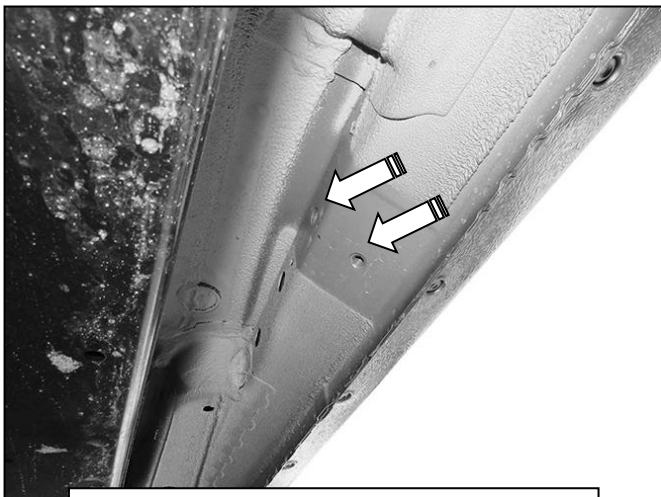

(Fig 3) Passenger/Right Center location

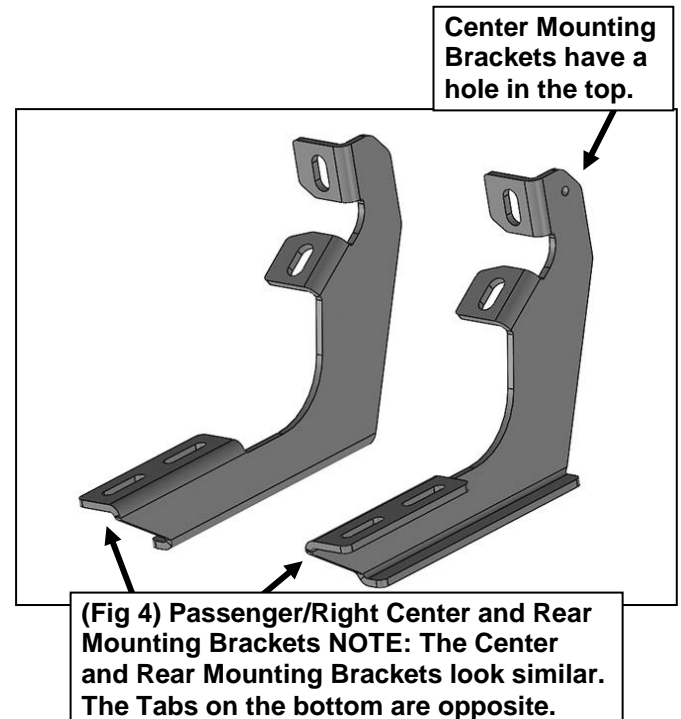

(Fig 4) Passenger/Right Center and Rear Mounting Brackets **NOTE:** The Center and Rear Mounting Brackets look similar. The Tabs on the bottom are opposite.

Passenger/Right Side Installation Pictured

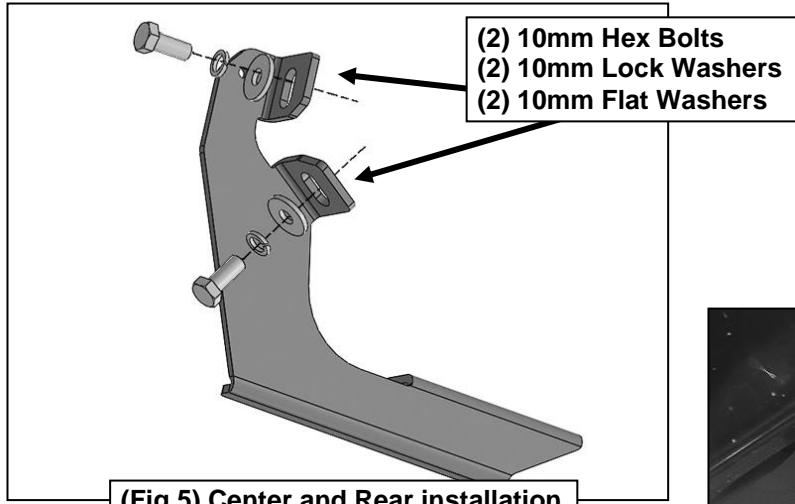

(Fig 5) Center and Rear installation
(Center Bracket pictured)

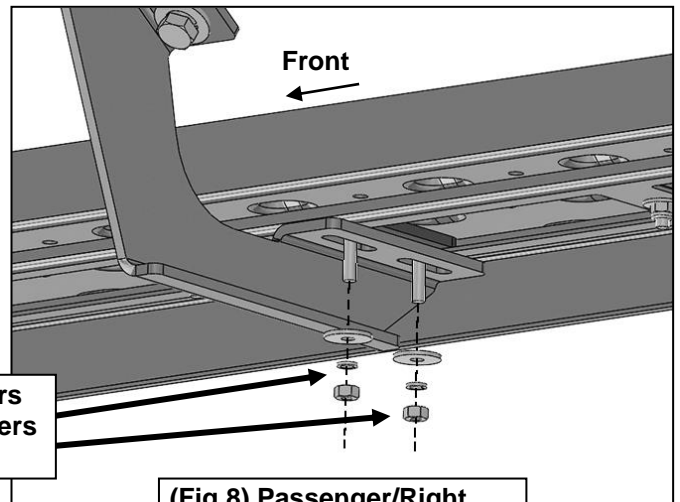
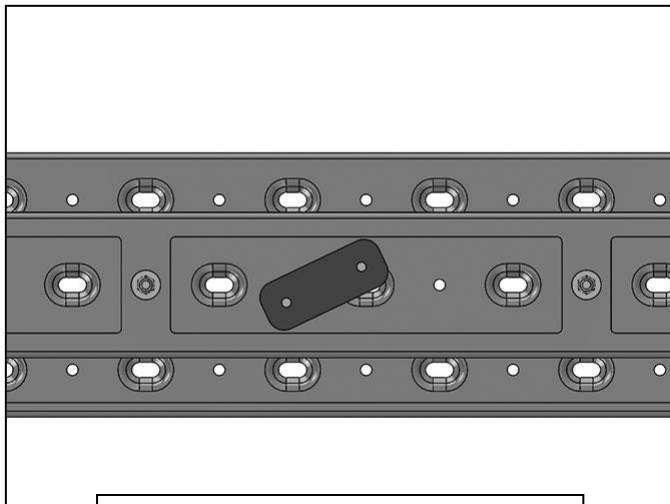
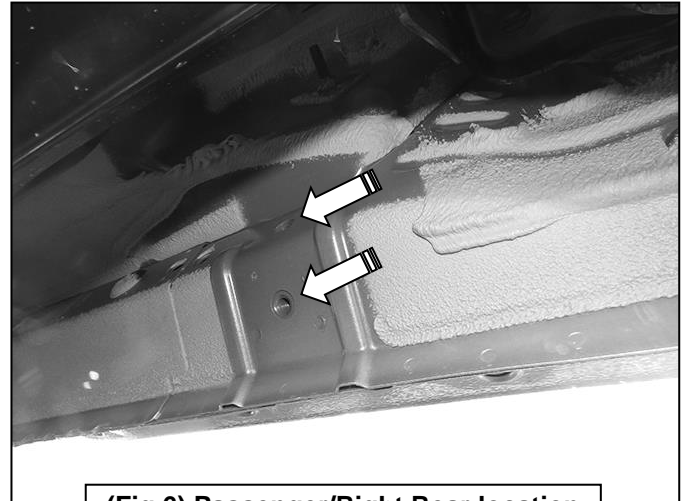

No.	Parts Identification
1	Passenger / Right 'Rear' Bracket marked "PR"
2	Driver / Left 'Rear' Bracket marked "DR"
3	Passenger / Right 'Center' Bracket marked "PC"
4	Driver / Left 'Center' Bracket marked "DC"
5	Passenger / Right 'Front' Bracket marked "PF"
6	Driver / Left 'Front' Bracket marked "DF"

Note:

- This guide is to identify the parts and not a reference for part count.
- For part count, refer Parts List.
- Product / Bracket image is representative and actual design may vary.

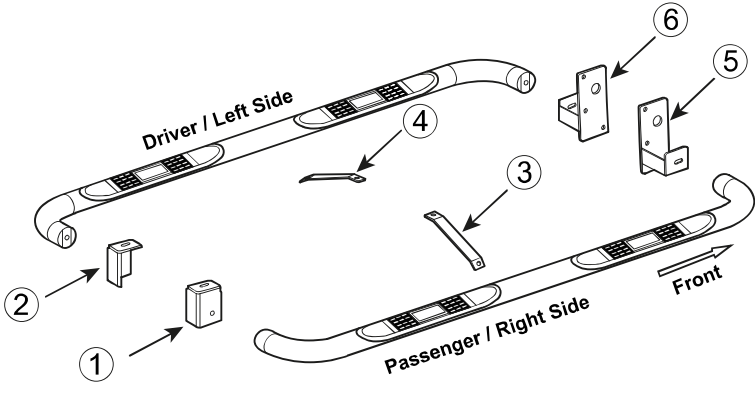

PRODUCT CARE

- Periodically check the product to ensure all fasteners are tight and components are intact.
- Regular waxing is recommended to protect the finish of the product.
- **Use ONLY Non-Abrasive automotive wax.** Use of any soap, polish or wax that contains an abrasive is detrimental and can scratch the finish leading to corrosion.
- Aluminum polish may be used to polish small scratches and scuffs for **Stainless Steel finish.**
- Mild soap may be used to clean the product for both **Stainless Steel and Black finish.**

FAQ's

1. Hardware's are not of correct size.

In GMC / Chevrolet truck model 2006 & up, customer needs to reuse the factory body bolts to install the bracket. If your vehicle is not GMC / Chevrolet 2006 & up, ensure that holes are not partially covered with any plastic grommet or rust? If it is, remove the plastic grommet & rust from the thread holes & re-try the installation.

2. Mounting Bracket are not getting Installed properly.

In some cases Illustration images shown in Installation manual may not be the exactly same as per actual vehicle images ,also if Driver / Passenger side mounting brackets are very identical in the design, suggest referring Parts Identification guide to avoid fitment issue.

3. Products are thumping / rattling after installation.

Ensure that all required mounting brackets / hardware's are installed & tighten correctly. Suggest using white lithium / regular grease between the metal to metal contact surfaces.

4. Side Bar is not aligning with vehicle / Step Pads are not aligning with vehicle doors.

Side bar may be interchanged or mounting brackets are not installed at the correct position in the vehicle. Refer Parts identification guide.

5. Missing / Excess Hardware.

Recheck hardware count as per the part list.

6. Product not installing properly.

Ensure make model year, cab length and bed size of your vehicle is listed in the application. All installation steps are followed correctly.

Check out these other TrailFX Products!!

www.TrailFX.com



Keystone Automotive Operations Inc. (KAO) warrants this product to be free of defects in material and workmanship at the time of purchase by the original retail consumer. KAO disclaims any other warranties, express or implied, including the warranty of fitness for a particular purpose or an intended use. If the product is found to be defective, KAO may replace or repair the product at our option, when the product is returned prepaid, with proof of purchase. Alteration to, improper installation, or misuse of this product voids the warranty. KAO's liability is limited to repair or replacement of products found to be defective, and specifically excludes liability for any incidental or consequential loss or damage.